

# DATA SHEET

## **FI1236MK2**

Desktop video tuner  
system RTMA M/N

Preliminary specification  
File under BU Tuners, DC03

1996 Mar 19

## Desktop video tuner system RTMA M/N

## FI1236MK2

### FEATURES

- System RTMA M and N
- True 5 V device (low power dissipation)
- Full frequency range from channel 2 (55.25 MHz) to channel 69 (801.25 MHz)
- PLL controlled tuning
- True-synchronous vision IF demodulator (PLL)
- Demodulated video output, AF sound output, second sound IF output
- I<sup>2</sup>C-bus control of tuning, address selection, AFC status information
- Complies with FCC and DOC regulations on radiation
- Small horizontally mounted metal housing.

### DESCRIPTION

The FI1236MK2 is designed to meet a wide range of RF applications in the PC Multi-Media environment.

The FI1236MK2 types are available with a single 75  $\Omega$  input for TV reception. The input connector is available in either standard phono (female socket) or F (female socket).

The tuning and bandswitching are performed through the built-in digitally controlled I<sup>2</sup>C-bus. All front-ends meet the FCC and DOC radiation requirements.

The FI1236MK2 consists of a tuner section and an IF section, which are all designed on a single PCB. The front-end is assembled in a metal housing made of a rectangular tin plated steel frame with front and rear covers which have soldered contacts to the frame. A single phono or F aerial socket is mounted on one side of the frame. All other connections are made via pins at the bottom.

The tuner section is equipped with 3 tuned RF MOSFET input stages, with a 3-band mixer-oscillator IC, containing the oscillators, mixers and IF amplifier. Tuning and band switching in the tuner section are done with a digital programmable PLL tuning system. This enables tuning with step-size programmable between 31.25, 50.0 or 62.5 kHz. A DC-DC converter is built around the PLL synthesizer IC to provide the tuning voltage, thus making the FI1236MK2 front-end a true 5 V device.

The IF section uses a true-synchronous vision IF demodulator (PLL) with an intercarrier SAW filter in front of it. The analog AFC voltage is fed to the 5-level A/D converter in the PLL tuning IC, so that the AFC status can be read via the I<sup>2</sup>C-bus.



### ORDERING INFORMATION

TYPE	CONNECTOR	CATALOGUE NUMBERS
FI1236MK2/HM/PH	standard phono	3139 147 13251
FI1236MK2/HM/F	F	3139 147 13261

### MARKING

The following items of information are printed on a sticker that is on the top cover of the tuner:

- Type number
- Code number
- Origin letter of factory
- Change code
- Year and week code.

### INTERMEDIATE FREQUENCIES

SYSTEM	FREQUENCY <sup>(1)</sup> (MHz)
	NTSC M/N
Picture carrier	45.75
Colour	42.17
Sound	41.25

### Note

1. The oscillator frequency is above the input signal frequency.

### CHANNEL COVERAGE

BAND	CHANNELS
Low band	55.25 to 160.00 MHz
Mid band	160.00 to 454.00 MHz
High band	454.00 to 801.25 MHz

Desktop video tuner  
system RTMA M/N

F11236MK2

BLOCK DIAGRAM

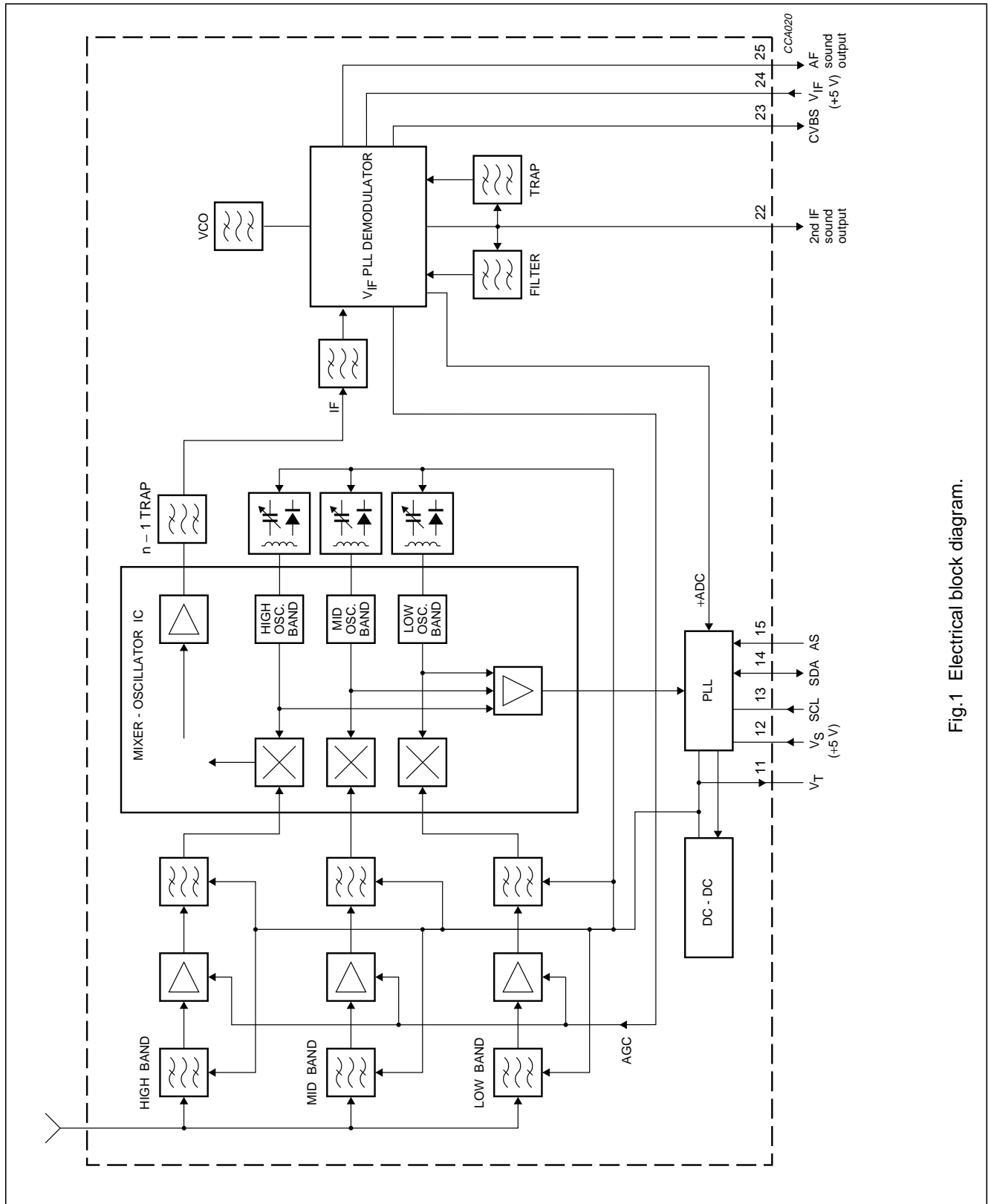

Fig.1 Electrical block diagram.

---

**Desktop video tuner  
system RTMA M/N**

---

**F11236MK2****PINNING**

<b>SYMBOL</b>	<b>PIN</b>	<b>DESCRIPTION</b>
V <sub>T</sub>	11	tuning voltage (monitor)
V <sub>S</sub>	12	supply voltage tuner section +5 V
SCL	13	I <sup>2</sup> C-bus serial clock
SDA	14	I <sup>2</sup> C-bus serial data
AS	15	I <sup>2</sup> C-bus address select
n.c.	21	not connected
2 <sup>nd</sup> IF sound output	22	second IF sound output
CVBS	23	Composite Video Baseband Signal output
V <sub>IF</sub>	24	supply voltage IF section +5 V
AF sound output	25	AF sound output
–	TH1, TH2, TH3 and TH4	mounting tags (ground)

# Desktop video tuner system RTMA M/N

FI1236MK2

## LIMITING VALUES

### Limiting values under operational conditions

The tuner can be guaranteed to function properly under the following conditions.

SYMBOL	PARAMETER	PIN	MIN.	TYP.	MAX.	UNIT
$V_S$	supply voltage	12	4.75	5.00	5.25	V
$V_{S(\text{ripple})}$	peak-to-peak ripple voltage susceptibility (at 5 V $\pm$ 5%); note 1 20 Hz to 100 kHz >100 kHz to 500 kHz		–	–	20	mV
			–	–	10	mV
$I_S$	supply current		–	–	120	mA
$V_{SCL}$	SCL bus input voltage	13	–0.3	–	+5.25	V
$V_{SDA}$	SDA bus input voltage	14	–0.3	–	+5.25	V
$I_{SDA}$	SDA bus current (open collector)		–1	–	+5	mA
$V_{AS}$	address select voltage; note 2	15	–	–	+5.25	V
$Z_{IF}$	2 <sup>nd</sup> IF sound output load impedance: DC AC	22	0.5	–	–	k $\Omega$
			0.5	–	–	k $\Omega$
$Z_{CVBS}$	Composite Video Baseband Signal load impedance: DC AC	23	–	75	–	$\Omega$
			–	75	–	$\Omega$
$t_L$	load time constant		–	–	100	ns
$V_{IF}$	IF supply voltage	24	4.75	5.0	5.25	V
$V_{IF(\text{ripple})}$	peak-to-peak ripple voltage susceptibility (at 5 V $\pm$ 5%); note 1 20 Hz to 100 kHz >100 kHz to 500 kHz		–	–	20	mV
			–	–	10	mV
$I_{IF}$	IF supply current		–	–	100	mA
$Z_{AF}$	AF sound output load impedance: DC AC	25	1.0	–	–	k $\Omega$
			0.6	–	–	k $\Omega$

### Notes

1. Sinusoidal ripple voltage superimposed on the 5 V supply voltage in the frequency range of 20 Hz to 500 kHz. Criteria for TV interference >57 dB.
2. For detailed information about the address decoding, refer to Chapter "Application information".

# Desktop video tuner system RTMA M/N

FI1236MK2

## Environmental conditions

SYMBOL	PARAMETER	CONDITIONS	MIN.	TYP.	MAX.	UNIT
<b>Non-operational conditions</b>						
T <sub>amb</sub>	ambient temperature		-25	-	+85	°C
RH	relative humidity		-	-	100	%
g <sub>B</sub>	bump acceleration	25 g	-	-	245	m/s <sup>2</sup>
g <sub>S</sub>	shock acceleration	50 g	-	-	490	m/s <sup>2</sup>
	vibration amplitude	10 to 55 Hz	-	0.35	-	mm
<b>Operational conditions</b>						
T <sub>amb</sub>	ambient temperature		-10	-	+60	°C
RH	relative humidity		-	-	95	%

## OVERALL PERFORMANCE

### Conditional data

Unless otherwise specified, all electrical values for Chapter "Overall performance" apply at the following conditions.

SYMBOL	PARAMETER	VALUE	UNIT
T <sub>amb</sub>	ambient temperature	25 ±5	°C
RH	relative humidity	60 ±15	%
V <sub>S</sub>	supply voltage (tuner and IF section)	5 ±0.125	V
Z <sub>CVBS</sub>	video output load impedance (DC)	>75	Ω
Z <sub>IF</sub>	IF sound output load impedance (DC)	>500	Ω
t <sub>pr</sub>	pre-heating time (+5 V at pin 24)	10	minute
Z <sub>S(AE)</sub>	aerial source impedance (unbalanced)	75	Ω

# Desktop video tuner system RTMA M/N

FI1236MK2

## TUNER SECTION

### Tuner characteristics

For detailed information about the PLL programming, refer to Chapter "Application information".

The desktop video tuner is guaranteed to function properly within the specified operational conditions, but a certain deterioration of performance parameters may occur at the limits of the operational conditions.

### Test equipment

EQUIPMENT	PARAMETER	VALUE	UNIT
DC voltmeter	input impedance	>1	MΩ
Oscilloscope	input impedance: resistance capacitance	>1 <15	MΩ pF
Spectrum analyzer	input impedance	50	Ω
FET probe	input impedance: resistance capacitance	1 3.5	MΩ pF
	output impedance	50	Ω
	voltage gain	0	dB

Desktop video tuner  
system RTMA M/N

F11236MK2

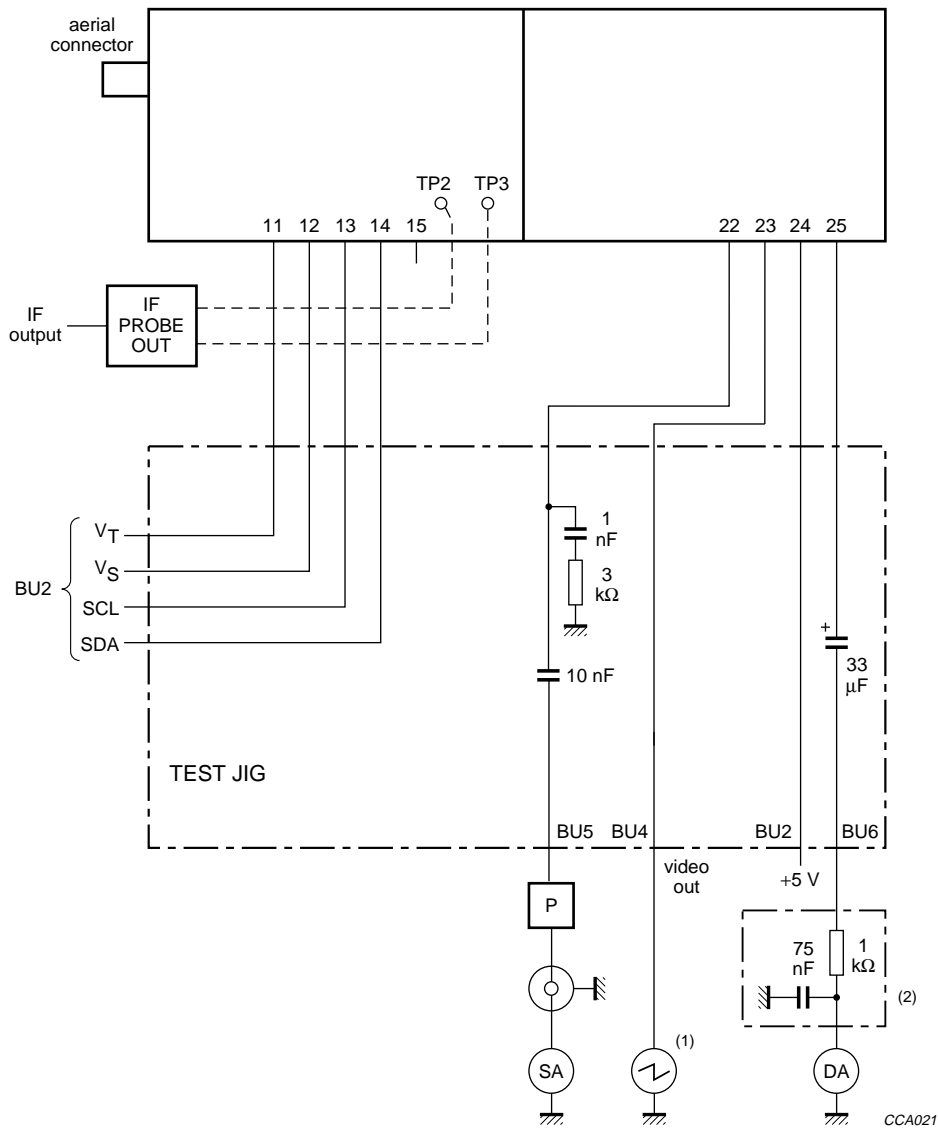

(1) BU4 loaded with 75 Ω.

(2) 75 μs de-emphasis.

SA = spectrum analyzer.

P = FET probe.

DA = distortion analyzer.

The minimum load impedance required at the CVBS output (pin 23) is 75 Ω (both AC and DC).

Fig.2 Typical test set up.

# Desktop video tuner system RTMA M/N

## F11236MK2

### Definitions of test signals (see Fig.2)

TEST SIGNAL	FREQ. (MHz)	AMPLITUDE	MODULATION	
			VIDEO	AUDIO
A0: unmodulated vision carrier	477.25	60 dB $\mu$ V		
A1: RTMA M/N standard signal with video modulation	477.25	60 dB $\mu$ V (top sync)	100% (rest carrier 12.5%) 2T pulse and bar	
B1: unmodulated sound carrier M system	481.25	-7 dB w.r.t. A0 to A1		
B2: FM modulated sound carrier M system	481.25	-7 dB w.r.t. A0 to A1		1 kHz; modulation frequency deviation $\pm 25$ kHz; 75 $\mu$ s pre-emphasis
B3: unmodulated sound carrier M system	483.25	-12 dB w.r.t. A0 to A1		

### Aerial input characteristics

SYMBOL	PARAMETER	CONDITIONS	MIN.	MAX.	UNIT
VSWR	reflection coefficient	referred to 75 $\Omega$ impedance (worst case on or between picture and sound carrier at maximum gain)	-	5	
V <sub>PSM</sub>	surge protection voltage		5	-	kV
V <sub>ant</sub>	antenna connection disturbance voltage	54 MHz to <300 MHz	-	34	dB $\mu$ V
		300 MHz to <1 000 MHz	-	50	dB $\mu$ V

# Desktop video tuner system RTMA M/N

FI1236MK2

## General characteristics

SYMBOL	PARAMETER	CONDITIONS	MIN.	TYP.	MAX.	UNIT
$f_b$	frequency range:					
	low band		55.25	–	157.25	MHz
	mid band		163.25	–	451.25	MHz
	high band		457.25	–	801.25	MHz
$\Delta f_b$	margin:					
	for low band		1.5	–	–	MHz
	for mid/high band		3	–	–	MHz
$\alpha_i$	image rejection (nominal gain to 10 dB gain reduction):					
	low band (channel 2 to 6)		60	–	–	dB
	mid band (channel 7 to 13)		60	–	–	dB
	high band (channel 14 to 69)		50	–	–	dB
$\alpha_{IF}$	IF rejection (picture)		60	–	–	dB
$Z_{IF}$	$\frac{1}{2}$ IF susceptibility:					
	channel 2 to 13		75	–	–	dB $\mu$ V
	channel 14 to 69		60	–	–	dB $\mu$ V
$m_x$	cross modulation:					
	in-channel		65	–	–	dB $\mu$ V
	in-band					
	low band ( $n \pm 2$ )		78	–	–	dB $\mu$ V
	mid band ( $n \pm 3$ )		78	–	–	dB $\mu$ V
high band ( $n \pm 5$ )		84	–	–	dB $\mu$ V	
	out of band		–	100	–	dB $\mu$ V
	breakthrough susceptibility:					
	channel 2 to 69		60	–	–	dB $\mu$ V
$V_{osc}$	oscillator voltage at all pins		–	–	70	dB $\mu$ V
$t_{li}$	oscillators lock-in time	charge pump set logic HIGH	–	–	150	ms
$\alpha_{vs}$	the video signal-to-sound interference ratio with the tuner exposed to sound signals in the audio frequency range 100 Hz to 10 kHz and sound pressure levels up to 105 dB (20 $\mu$ Pa)		40	–	–	dB
$V_{ESD}$	electrostatic discharge (ESD) on all pins	note 1	2	–	–	kV

### Note

- All the pins of the desktop video tuner are protected against electrostatic discharge (ESD) up to 2 kV. The product is classified in category B ("MIL-STD-883C").

# Desktop video tuner system RTMA M/N

FI1236MK2

## Video and audio characteristics (see Fig.2)

PARAMETER	TEST SIGNAL	TEST POINT	MIN.	TYP.	MAX.	UNIT
CVBS characteristics:						
video amplitude signal at pin 23	A1 (peak-to-peak value)	BU4	0.7	–	1.1	V
DC level sync pulse at pin 23	A1	BU4	–	0.35	–	V
Video amplitude drop with respect to modulation 0.1 MHz at $T_{amb} = 45\text{ }^{\circ}\text{C}$ :						
at 1 MHz	A1	BU4	–1.0	–	+1.0	dB
at 2 MHz	A1	BU4	–1.5	–	+1.5	dB
at 3 MHz	A1	BU4	–2.5	–	+1.5	dB
at 3.58 MHz	A1	BU4	–4.0	–	+2.0	dB
Sound carrier rejection	A1 (1 MHz) + B1	BU4	40	–	–	dB
Residual 47.25 MHz signal in video channel: level of 1.5 MHz	A1 + B3	BU4	–	–	68	dB $\mu$ V
Residual 91.5 MHz signal in video channel	A1	BU4	–	–	80	dB $\mu$ V
Second IF sound output level at level of 4.5 MHz	A1 + B1	BU5	84	–	–	dB $\mu$ V
Test on 2T pulse at $T_{amb} = 45\text{ }^{\circ}\text{C}$ :						
2T pulse/bar response	A1	BU4	–2.5	–	+2.5	%
2T pulse response	A1	BU4	–	–	+3.0	%
CVBS S/N (unweighted)	A1 + B1	BU4	41	–	–	dB
Gain limited sensitivity at 1 dB reduction of video output	A1	BU4	–	–	30	dB $\mu$ V
Audio characteristics:						
AF output level measured via LP 20 kHz filter, RMS detector, 75 $\mu$ s de-emphasis	A1 + B2	BU6	0.25	0.35	0.50	V
THD (Total Harmonic Distortion) measured via LP 20 kHz filter, RMS detector, 75 $\mu$ s de-emphasis	A1 + B2	BU6	–	–	0.5	%
S/N measured via CCIR filter, peak CCIR detector, 75 $\mu$ s de-emphasis	A1 (full field colour bar) + B1	BU6	41	–	–	dB
AF 3 dB response measured via LP 20 kHz filter, RMS detector, de-emphasis off	A1 (black) + B1	BU6	90	–	–	kHz
AM suppression ratio	A1 + B2	BU6	40	–	–	dB

## Digital AFC status

PARAMETER	CONDITIONS	FREQUENCY (kHz)	DIGITAL READ-OUT
ADC word at I <sup>2</sup> C-bus during read operation	input voltage at pin 10:		
	0.0 to 0.15V <sub>S</sub>	–125	00
	0.15 to 0.30V <sub>S</sub>	–62.5	01
	0.30 to 0.45V <sub>S</sub>	0	02
	0.45 to 0.60V <sub>S</sub>	+62.5	03
	0.60 to 1.00V <sub>S</sub>	+125	04

## Desktop video tuner system RTMA M/N

FI1236MK2

### APPLICATION INFORMATION

A detailed description of the I<sup>2</sup>C-bus specification, with applications, is given in brochure "The I<sup>2</sup>C-bus and how to use it". This brochure may be ordered using the code number 9398 393 40011.

### WRITE mode

BYTE	BITS								
	7 MSB	6	5	4	3	2	1	0 LSB	A <sup>(1)</sup>
Address byte	1	1	0	0	0	MA1	MA0	0	A
Program divider byte 1	0	n14	n13	n12	n11	n10	n9	n8	A
Program divider byte 2	n7	n6	n5	n4	n3	n2	n1	n0	A
Control information byte 1	1	CP	T2	T1	T0	RSA	RSB	OS	A
Control information byte 2	P7	P6	P5	P4	P3	P2	P1	P0	A

### Note

1. A = Acknowledge.

### ADDRESS SELECTION

V<sub>S</sub> = +5 V (PLL supply voltage)

MA1	MA0	ADDRESS	VOLTAGE AT PIN 15
0	0	C0	0 to 0.1V <sub>S</sub>
0	1	C2	0.2 to 0.3V <sub>S</sub>
1	0	C4	0.4 to 0.6V <sub>S</sub>
1	1	C6	0.9V <sub>S</sub> to V <sub>S</sub>

### PROGRAMMABLE DIVIDER SETTINGS (BYTES 1 AND 2)

Divider ratio:

$N = 16 \times \{f_{RF(pc)} + f_{IF(pc)}\}$ , where (pc) is picture carrier and  $f_{RF}$  and  $f_{IF}$  are expressed in MHz.

$f_{osc} = N/16$  (MHz).

$N = (8192 \times n13) + (4096 \times n12) + (2048 \times n11) + (1024 \times n10) + (512 \times n9) + (256 \times n8) + (128 \times n7) + (64 \times n6) + (32 \times n5) + (16 \times n4) + (8 \times n3) + (4 \times n2) + (2 \times n1) + n0$

### CONTROL BYTE

Charge pump settings:

CP = 1, for fast tuning

CP = 0, for moderate speed tuning with slightly better residual oscillator FM.

Test mode settings:

T2 = T1 = 0; T0 = 1, for normal operation.

PLL disabling:

OS = 0, for normal operation

OS = 1, for switching the charge pump to the high impedance state.

## Desktop video tuner system RTMA M/N

FI1236MK2

### Ratio select bits

RSA	RSB	STEP SIZE
X	0	50 kHz
0	1	31.25 kHz (for slow picture search)
1	1	62.5 kHz (for normal picture search)

### PORTS BYTE

### Band switching

BAND	BIT <sup>(1)</sup>							
	P0	P1	P2	P3 <sup>(2)</sup>	P4	P5	P6	P7
Low band	0	0	0	X	0	1	0	1
Mid band	0	0	0	X	1	0	0	1
High band	0	0	0	X	1	1	0	0

### Notes

1. X = don't care; P0 to P7 are output ports on the PLL device.
2. P3 is a system switch output for customer applications.

### TELEGRAM EXAMPLES (WRITE MODE)

Start - Adb - Ack - Db1 - Ack - Db2 - Ack - Cb - Ack - Pb - Ack - Stop.

Start - Adb - Ack - Cb - Ack - Pb - Ack - Db1 - Ack - Db2 - Ack - Stop.

Start - Adb - Ack - Db1 - Ack - Db2 - Ack - Cb - Ack - Stop.

Start - Adb - Ack - Db1 - Ack - Db2 - Ack - Stop.

Where:

Start = start condition

Adb = address byte

Ack = acknowledge

Db1 = divider byte 1

Db2 = divider byte 2

Cb = control byte

Pb = ports byte

Stop = stop condition.

**Remark:** for channel selection involving band switching, and to ensure smooth tuning to the desired channel without causing unnecessary charge pump action, it is recommended to consider the difference between wanted channel frequency ( $f_w$ ) and the current channel frequency ( $f_c$ ):

- If  $f_w > f_c$ , use telegram as:  
Start - Adb - Ack - Db1 - Ack - Db2 - Ack - Cb - Ack - Pb - Ack - Stop
- If  $f_w < f_c$ , use telegram as:  
Start - Adb - Ack - Cb - Ack - Pb - Ack - Db1 - Ack - Db2 - Ack - Stop.

Unnecessary charge pump action will result in very low tuning voltage ( $V_T \approx 0$  V) which may drive the oscillator to extreme conditions.

# Desktop video tuner system RTMA M/N

F11236MK2

### READ mode

The in-lock can be read by setting the R/W bit to 1.

BYTE	BITS								
	7 MSB	6	5	4	3	2	1	0 LSB	A <sup>(5)</sup>
Address byte	1	1	0	0	0	MA1	MA0	1	A
Status byte	POR <sup>(1)</sup>	FL <sup>(2)</sup>	I2 <sup>(3)</sup>	I1 <sup>(3)</sup>	I0 <sup>(3)</sup>	A2 <sup>(4)</sup>	A1 <sup>(4)</sup>	A0 <sup>(4)</sup>	A

### Notes

1. POR = Power On Reset. POR is internally set to 1 in case  $V_S$  drops below 3 V. The POR bit is reset when an end of data is detected by the PLL IC.
2. FL = In-lock flag; FL = 1: loop is phase-locked. The loop must be phase-locked during at least 8 periods of the internal 7.8125 kHz reference frequency before the FL flag is internally set to 1.
3. I2, I1 and I0 = digital information for I/O ports P2, P1 and P0 respectively.
4. A2, A1 and A0 = built-in 5-level A/D converter on I/O port P6. AFC information to the controller of the IF section is available on pin 10 (see Table "Digital AFC status").
5. A = Acknowledge.

### TELEGRAM EXAMPLES (READ MODE)

Start - Adb - Ack - STB - Ack - STB - - Stop (no Ack from processor = End-of-data).

Start - Adb - Ack - STB - - Stop (no Ack from processor = End-of-data).

Where:

STB = Status byte.

### Video buffer

A video buffer is built into the video module to enable the unit to drive a 75 Ω load directly. In case it is required to use the F11236MK2 as a replacement for the F11236 in the same videocard, it is necessary to replace the 75 Ω series resistor in the video card by a 0 Ω series resistor. At the same time the 22 kΩ series resistor in the tuning supply must be removed.

### I<sup>2</sup>C-bus load

The F11236MK2 contains a series resistor ( $R = 100 \Omega$ ) in the SCL and SDA lines. Both lines also have a capacitive load of typical 56 pF (see Fig.3).

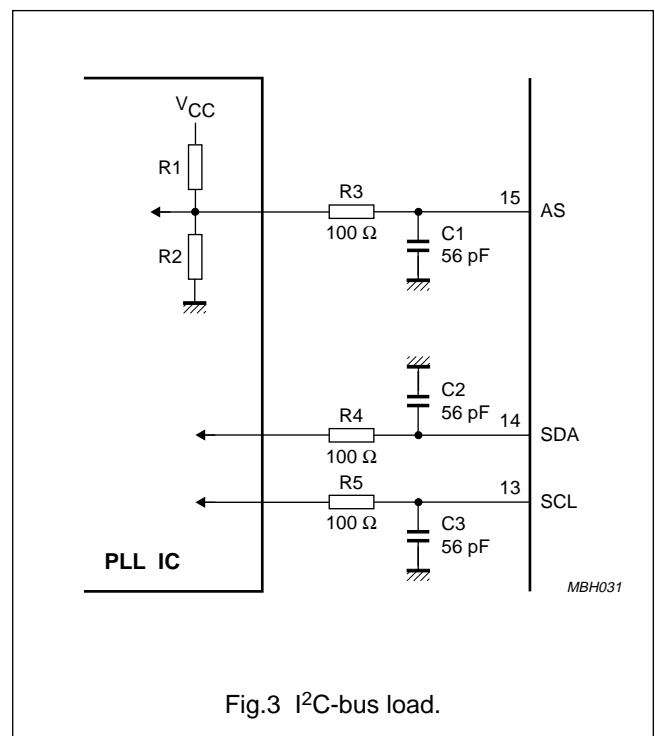
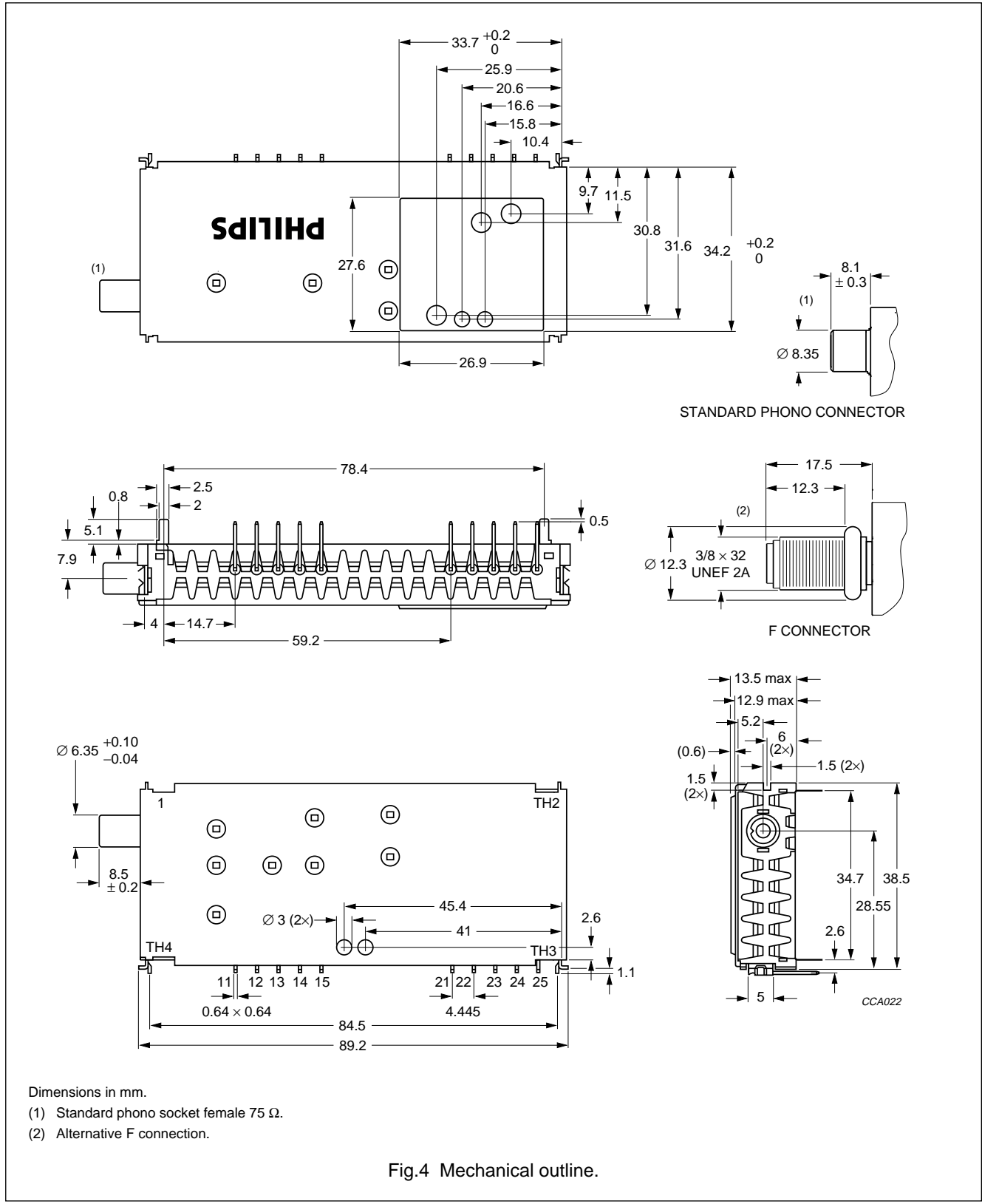

Fig.3 I<sup>2</sup>C-bus load.

Desktop video tuner  
system RTMA M/N

FI1236MK2

MECHANICAL DATA



Dimensions in mm.

(1) Standard phono socket female 75  $\Omega$ .

(2) Alternative F connection.

Fig.4 Mechanical outline.

# Desktop video tuner system RTMA M/N

F11236MK2

### Aerial connections

Standard-phono socket female 75 Ω or F (female).

### Solderability

The solderability of pins and mounting tags when tested initially and after 16 hours steam ageing in accordance with "IEC 68-2-20", test Ta, method 1 (solder bath 235 °C for 2 s), results in a wetted area of 95%. No de-wetting will occur when soldered at 260 °C for 5 s.

### Resistance to soldering heat

The product will not be damaged when tested in accordance with "IEC 68-2-20", test Tb, method 1A (solder bath 260 °C for 10 ± 1 s).

### Mass

Approximately 50 g.

### Robustness of pins

The pins will not be damaged when tested in accordance with "IEC 68-2-21":

- Test Ua1, tensile of 10 N in axial direction
- Test Ua2, thrust of 4 N in axial direction.

### Punching pattern of chassis PCB

Field rejects are often related to broken tag joints. Therefore, the following punching pattern is recommended (see Fig.5).

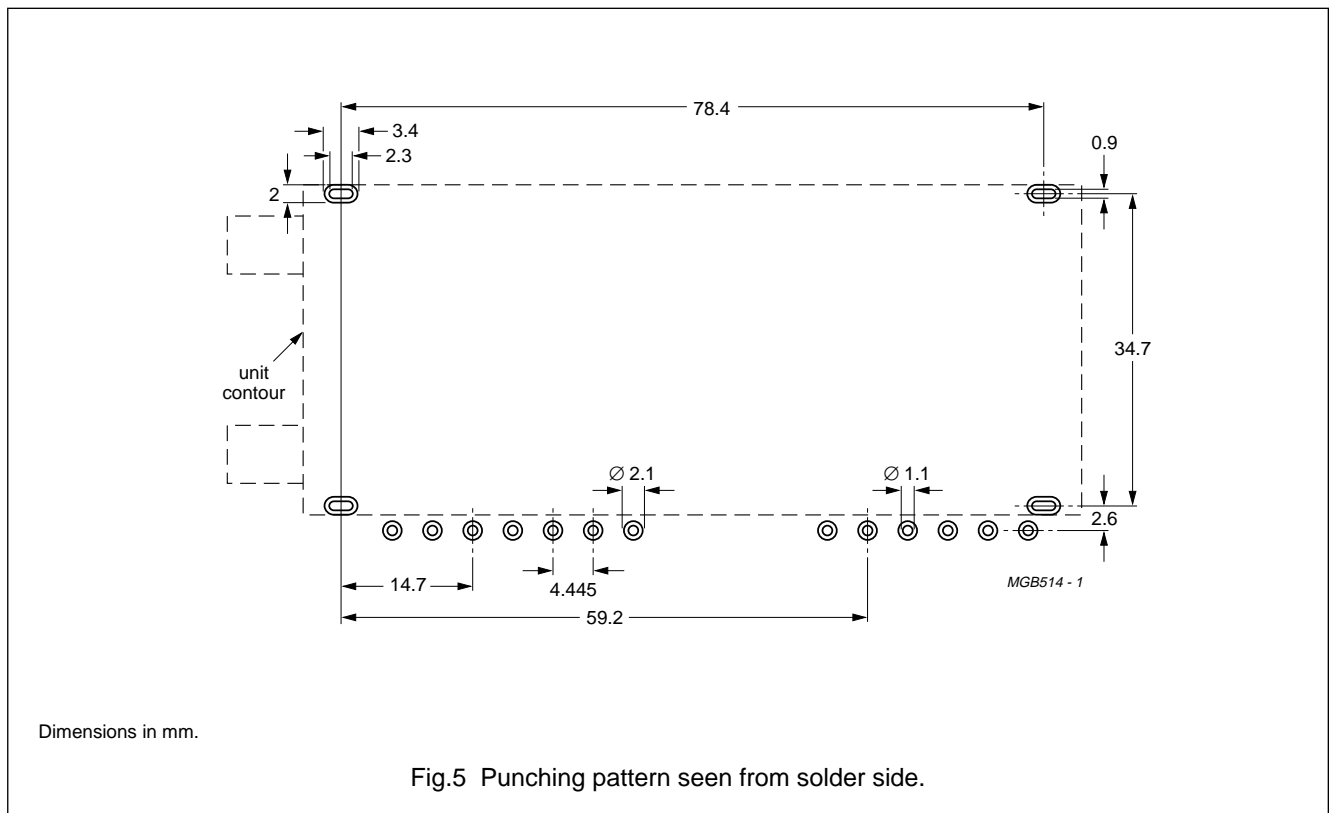

## Desktop video tuner system RTMA M/N

F11236MK2

### DEFINITIONS

<b>Data sheet status</b>	
Objective specification	This data sheet contains target or goal specifications for product development.
Preliminary specification	This data sheet contains preliminary data; supplementary data may be published later.
Product specification	This data sheet contains final product specifications.
<b>Application information</b>	
Where application information is given, it is advisory and does not form part of the specification.	

### LIFE SUPPORT APPLICATIONS

These products are not designed for use in life support appliances, devices, or systems where malfunction of these products can reasonably be expected to result in personal injury. Philips customers using or selling these products for use in such applications do so at their own risk and agree to fully indemnify Philips for any damages resulting from such improper use or sale.

### PURCHASE OF PHILIPS I<sup>2</sup>C COMPONENTS



Purchase of Philips I<sup>2</sup>C components conveys a license under the Philips' I<sup>2</sup>C patent to use the components in the I<sup>2</sup>C system provided the system conforms to the I<sup>2</sup>C specification defined by Philips. This specification can be ordered using the code 9398 393 40011.

---

Desktop video tuner  
system RTMA M/N

---

F11236MK2

**NOTES**

---

Desktop video tuner  
system RTMA M/N

---

F11236MK2

**NOTES**

## Philips Components – a worldwide company

- Argentina:** IEROD, Av. Juramento, 1991-14.B, (1428) BUENOS AIRES, Tel. (541) 786 7635, Fax. (541)786 9367.
- Australia:** PHILIPS COMPONENTS PTY Ltd, 34 Waterloo Road, NORTH RYDE NSW 2113, Tel. (02)805 4455, Fax. (02)805 4466.
- Austria:** PHILIPS COMPONENTS, Vertriebsgesellschaft m.b.H., Triester Strasse 64, A-1101 WIEN, P.O. Box 213, Tel. (01)601 01 12 12, Fax. (01)60 101 12 10.
- Belgium:** PHILIPS NEDERLAND B.V., Philips Components & Semiconductors, Postbus 90050, 5600 PB EINDHOVEN, Netherlands, Tel. (31)40 2783 749, Fax. (31)40 2788 399.
- Brazil:** PHILIPS COMPONENTS, Rua do Rocio 220 - 5<sup>th</sup> floor, 04552-903 - SÃO PAULO - SP, Tel. (011)821 2333, Fax. (011)829 1849.
- Canada:** PHILIPS ELECTRONICS Ltd., Philips Components, 601 Milner Ave., SCARBOROUGH, Ontario, M1B 1M8, Tel. (0416)292 5161, Fax. (0416)754 6248.
- Chile:** PHILIPS CHILENA S.A., Av. Santa Maria 0760, SANTIAGO, Tel. (02)77 38 16, Fax. (02)735 3594.
- China:** PHILIPS COMPANY, Philips Components MSO PRC, 6F Building 2, No. 889 Yi Shan Road, SHANGHAI 200233, Tel. (21)6 485 0600, Fax. (21)6 485 1014.
- Colombia:** IPRELENZO LTDA, Diagonal 59, No. 20-27, P.O. Box 77621, SANTA FE DE BOGOTÁ, Tel. (57)(1)345 8713, Fax. (57)(1)345 8712.
- Denmark:** PHILIPS COMPONENTS A/S, Prags Boulevard 80, P.O. Box 1919, 2300 COPENHAGEN S, Tel. 32 88 3333, Fax. 31 57 1949.
- Finland:** PHILIPS COMPONENTS, Sinikalliontie 3, FIN-02630 ESPOO, Tel. (9)0-615 800, Fax. (9)0-615 80920.
- France:** PHILIPS COMPOSANTS, 4 Rue du Port-aux-Vins, BP317, 92156 SURESNES, Cedex, Tel. (01)4099 6161, Fax. (01)4099 6427.
- Germany:** PHILIPS COMPONENTS UB der Philips G.m.b.H., P.O. Box 10 63 23, 20043 HAMBURG, Tel. (040)3296-0, Fax. (040)3296 213.
- Greece:** PHILIPS HELLENIQUE S.A., Components Division, No. 15, 25th March Street, GR 17778 TAVROS, Tel. (01)4894 339/(01)4894 911, Fax. (01)4815 180.
- Hong Kong:** PHILIPS HONG KONG, Components Division, Unit 003-005, G/F, Hong Kong Ind. Technology Centre, 72 Tat Chee Avenue, Kowloon Tong, KOWLOON, Tel. (852)2784 3000, Fax. (852)2784 3003.
- India:** Philips INDIA Ltd., Components Dept., Shivsagar Estate, A Block, Dr. Annie Besant Rd. Worli, Bombay 400 018, Tel. (022)4938 541, Fax. (022)4938 722.
- Indonesia:** P.T. PHILIPS DEVELOPMENT CORPORATION, Philips House, Jalan H.R. Rasuna Said Kav. 3-4, P.O. Box 4252, JAKARTA 12950, Tel. (021)5201122, Fax. (021)5205189.
- Ireland:** PHILIPS ELECTRONICS (IRELAND) Ltd., Components Division, Newstead, Clonskeagh, DUBLIN 14, Tel. (01)76 40 203, Fax. (01)76 40 210.
- Israel:** Rapac Electronics Ltd., 7 Kehilat Saloniki St. P.O. Box 18053, TEL AVIV 61180, Tel. (03)6450 444, Fax. (03)6491 007.
- Italy:** PHILIPS COMPONENTS S.r.l., Piazza IV Novembre 3, 20124 MILANO, Tel. (02)6752 2531, Fax. (02)6752 2557.
- Japan:** PHILIPS JAPAN Ltd., Components Division, Philips Bldg 13-37, Kohnan 2-chome, Minato-ku, TOKYO 108, Tel. (03)3740 5028, Fax. (03)3740 0580.
- Korea:** (Republic of): PHILIPS ELECTRONICS (KOREA) Ltd., Components Division, Philips House, 260-199 Itaewon-dong, Yongsan-ku, SEOUL, Tel. (02)709 -1472, Fax. (02)709 1479.
- Malaysia:** PHILIPS MALAYSIA SDN BERHAD, Components Division, No. 76 Jalan Universiti, 46200 Petaling Jaya, KUALA LUMPUR, Tel. (03)757 5511, Fax. (03)757 4880. PHILIPS MALAYSIA SDN BERHAD, Components Division, 345 Jalan Gelugor, PULAU PINANG, Tel. (04)870 055, Fax. (04)879 215.
- Mexico:** PHILIPS COMPONENTS, 5900 Gateway East, Suite 200, EL PASO, TX 79905, U.S.A., Tel. (915)772 4020, Fax. (915)772 4332.
- Netherlands:** PHILIPS NEDERLAND B.V., Philips Components & Semiconductors, Bldg. VB Postbus 90050, 5600 PB EINDHOVEN, Tel. (040)2783 749, Fax. (040)2788 399.
- New Zealand:** PHILIPS NEW ZEALAND Ltd., Components Division, 2 Wagener Place, C.P.O. Box 1041, AUCKLAND, Tel. (09)849 4160, Fax. (09)849 7811.
- Norway:** NORSK A/S PHILIPS, Philips Components, Box 1, Manglerud 0612, OSLO, Tel. 22 74 8000, Fax. 22 74 8341.
- Pakistan:** Philips Electrical Industries of Pakistan Ltd., Exchange Bldg. ST-2/A, Block 9, KDA Scheme 5, Clifton, KARACHI 75600, Tel. (021)587 4641-49, Fax. (021)577035/5874546.
- Philippines:** PHILIPS SEMICONDUCTORS PHILIPPINES Inc., 106 Valero St. Salcedo Village, P.O. Box 2108 MCC, MAKATI, Metro MANILA, Tel. (02)810-0161, Fax. (02)817-3474.
- Portugal:** PHILIPS PORTUGUESA, S.A., Rua dr. António Loureiro Borges 5, Arquiparque - Miraflores, Apartado 300, 2795 LINDA-A-VELHA, Tel. (01)4163160/4163333, Fax. (01)4163174/4163366.
- Singapore:** PHILIPS SINGAPORE, Pte Ltd., Components Division, Lorong 1, Toa Payoh, SINGAPORE 1231, Tel. (65)350 2000, Fax. (65)355 1758.
- South Africa:** S.A. PHILIPS Pty Ltd., Components Division, 195-215 Main Road Martindale, 2092 JOHANNESBURG, P.O. Box 7430 Johannesburg 2000, Tel. (011)470-5911, Fax. (011)470-5494.
- Spain:** PHILIPS COMPONENTS, Balmes 22, 08007 BARCELONA, Tel. (93)301 63 12, Fax. (93)301 42 43.
- Sweden:** PHILIPS COMPONENTS AB, Kottbygatan 7, Akalla. Postal address: S-164 85 STOCKHOLM, Tel. (+46)8 632 2000, Fax. (+46)8 632 2745.
- Switzerland:** PHILIPS COMPONENTS AG, Allmendstrasse 140, CH-8027 ZÜRICH, Tel. (01)488 22 11, Fax. (01)481 77 30.
- Taiwan:** PHILIPS TAIWAN Ltd., 23-30F, 66, Chung Hsiao West Road, Sec. 1, Taipei, Taiwan ROC, P.O. Box 22978, TAIPEI 100, Tel. (02)388 7666, Fax. (02)382 4382.
- Thailand:** PHILIPS ELECTRONICS (THAILAND) Ltd., 209/2 Sanpavuth-Bangna Road Prakanong, Bangkok 10260, THAILAND, Tel. (66)2 745 4090, Fax. (66)2 398 0793.
- Turkey:** Türk Philips Ticaret A.S., Components Department, Talatpasa Cad. No. 5, 80640 GÜLTEPE/İSTANBUL, Tel. 90-212-279-27-70, Fax. 90-212-282-67-07.
- United Kingdom:** PHILIPS COMPONENTS Ltd., The Mullard Building, Dorking Business Park, DORKING, Surrey, RH4 1HJ, Tel: (01306)512000, Fax: (01306)512345.
- United States:** PHILIPS COMPONENTS, Division Headquarters, 1440 Indiantown road Jupiter, FL 33458, Tel. (407)744 4200, Fax. (407)743 2113. For literature: (800)447 3762. PHILIPS DISPLAY COMPONENTS COMPANY, 1600 Huron Parkway, ANN ARBOR, Michigan 48105-2590, Tel. (313)996 9400, Fax. (313)761 2776.
- Uruguay:** PHILIPS COMPONENTS, Coronel Mora 433, MONTEVIDEO, Tel. (02)70-4044, Fax. (02)920 601.

**For all other countries apply to:** Philips Components, Marketing Communications, P.O. Box 218, 5600 MD EINDHOVEN, The Netherlands, Telex 35000 phtcnl, Fax. +31-40-2724 547.

COD04 © Philips Electronics N.V. 1996

All rights are reserved. Reproduction in whole or in part is prohibited without the prior written consent of the copyright owner.

The information presented in this document does not form part of any quotation or contract, is believed to be accurate and reliable and may be changed without notice. No liability will be accepted by the publisher for any consequence of its use. Publication thereof does not convey nor imply any license under patent- or other industrial or intellectual property rights.

Printed in The Netherlands